

Automatic, Continuous Food Volume Measurement with a Helmholtz Resonator

T. Nishizu*, Y. Ikeda*, Y. Torikata**, S. Manmoto**, T. Umehara**, and T. Mizukami**

* Department of Bioproduction Engineering, Graduate School of Agriculture,
Kyoto University, Kyoto 606-8502, Japan
Phone : +81-75-753-6318, Fax : +81-75-753-6171
E-mail : nishizu@e7sun-1.kais.kyoto-u.ac.jp

** Mayekawa MFG. CO., LTD., 2-13-1 Botan, Koto-ku, Tokyo 135-8482, Japan

ABSTRACT

An automatic and continuous volume measuring system was developed for agricultural products and foodstuffs. It could measure volume of objects loaded continuously onto the conveyor belt. Principle of measurement was based on a relationship between volume of an object in a Helmholtz resonator and an acoustic resonant frequency. For getting the resonant frequency, response signal corresponding to a chirp signal input into the resonator was analyzed by maximum entropy method. Volume of wooden, metallic blocks and boiled rice were used in a measurement test. The predicted value agreed very well with the real volume. The r^2 were 0.99, 0.99 and 0.97 at the conveyor speed of 15, 30 and 45mm/sec, respectively.

Keywords: Automatic and continuous volume measuring, Food, Agricultural products, Acoustic resonance, spectrum analysis, Maximum entropy method

INTRODUCTION

Density is one of the important quality indices for agricultural products (Zaltzman et al., 1987). Differences of density have been utilized for quality inspection such as seed viability test and citrus granulation test. Kato et al. (1992, 1997) reported that there is a close relationship between a melon's maturity and density. Sugiura et al. (1996) also reported such a relationship in peaches.

Density is calculated from mass and volume. Mass can be measured precisely and quickly with a digital scale. Volume measurement, however, is not so easy. There are two typical methods for measuring volume; the gas displacement method and the liquid displacement method. The liquid displacement method is a simple and easy way, but agricultural products or foodstuffs may be damaged by their immersion into liquid. The gas displacement method does not damage food seriously. But it requires quite a long time for measurement.

A volume measurement system for foodstuffs with a Helmholtz resonator has been developed to resolve the above-mentioned problems. A Helmholtz resonator looks

Nishizu, T., Y. Ikeda, Y. Torikata, S. Manmoto, T. Umehara, and T. Mizukami.
"Automatic, Continuous Food Volume Measurement with a Helmholtz Resonator". Agricultural Engineering International: the CIGR Journal of Scientific Research and Development. Manuscript FP 01 004. Vol. III.

like a wine bottle. It consists of a “throat” and another part called a “chamber” or “cavity”. Blowing or hitting the lip of the throat makes a sound which includes a resonant component. This component is called as Helmholtz resonant frequency. This resonant frequency depends on cavity volume minus its contents. As the volume of the contents decreases, the cavity volume increases. With nothing in the bottle, the cavity volume should be equal to the empty chamber’s volume. This means that resonant frequency provides the information regarding the contents’ volume. Besides liquid, volume of solid or gel-like objects in any shape can also be determined. It was already reported that this volume measuring system performed well ($r^2 > 0.97$) when measuring volume of water, clay, *adzuki* beans, apple and grapes (Nishizu 1995, 1998).

In post-harvesting and food-manufacturing processes, both batch and continuous processes are used. Such a bottle-shaped resonator may be applicable to a batch process, but not to a continuous process. In this paper a volume measuring system for a continuous process is introduced. A resonator has an inlet and an outlet through which foodstuffs are moved by a conveyor belt. A chirp wave sound was input inside the resonator and then a signal detected by a microphone was processed by spectrum analysis for obtaining Helmholtz resonant frequency depending on the object’s volume.

PRINCIPLE

Helmholtz Resonance and Volume Prediction

Blowing a lip of a resonator in Figure 1 utters a sound with a prominent peak frequency. It is known as the Helmholtz resonance phenomena. A resonant frequency depends on the object’s (water’s) volume in a resonator. Equation 1 expresses such a dependency.

$$f = [S / (l - l_c) / (W - V)]^{0.5} \cdot c / (2\pi) \quad (1)$$

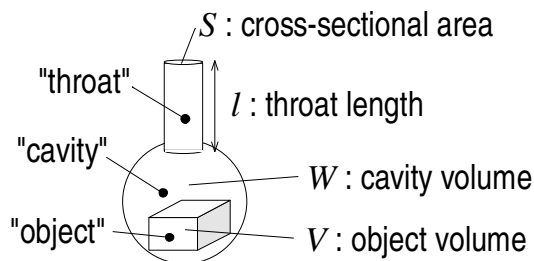

Figure 1. A Helmholtz resonator.

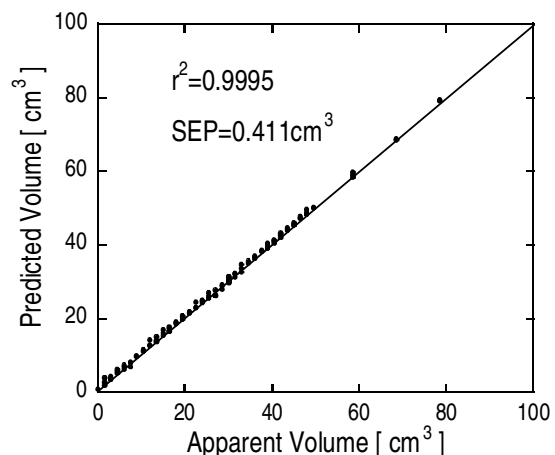

Figure 2. An result of volume prediction of water.

where f is resonant frequency [Hz], c is sound velocity in air [m/s], W is cavity volume [m^3], V is object volume [m^3], l is throat length [m], l_c is open end correction [m], and S is cross-sectional area of the throat [m^2]

By measuring the resonant frequency with some object in the resonator, the object's volume can be determined by Equation 1. For examining accuracy and precision of this method, volume of water in a 130cc-flask used as a Helmholtz resonator was predicted. (See Figure 2.) The predicted values agreed very well with true values. This means that this acoustic method is quite accurate.

Helmholtz resonator with a multi-tube

A cavity of a resonator shown in Figure 1 has one throat. Objects must be put into the resonator through this throat's lip. Such a resonator structure creates the difficulty of putting objects inside automatically and continuously.

If the bottom of the resonator is detachable from the cavity as shown in Figure 3, it may resolve such a problem. The detachable resonator can also be effective for an automatic and continuous measuring system with a conveyor belt. When an object is carried beneath this type of resonator, the resonator goes down to conceal it, and then the resonant frequency is measured for getting the object's volume. This way will require complete sealing between the cavity wall and the bottom plate. If sealing is not enough, resonant frequency will be shift and will cause a volume prediction error.

A new type of resonator was developed. It had both an inlet and an outlet on a cavity wall, as shown in Figure 4(d). This resonator is completely same as the resonator that is given by dividing one throat of the original resonator into three throats and placing two throats in one line. (See Figure 4(a)-(c).) Both openings are always open, and a conveyor belt passes through them. It will not cause a sealing problem and will make automatic and continuous measurement with a conveyor belt possible. Using an

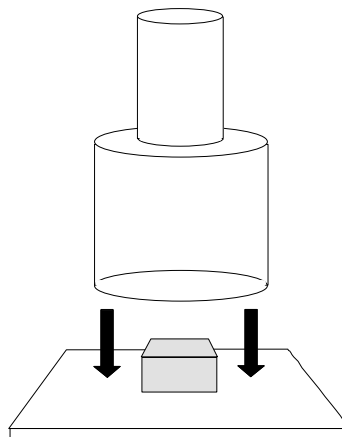

Figure 3. A schematic diagram of a resonator with a detachable bottom.

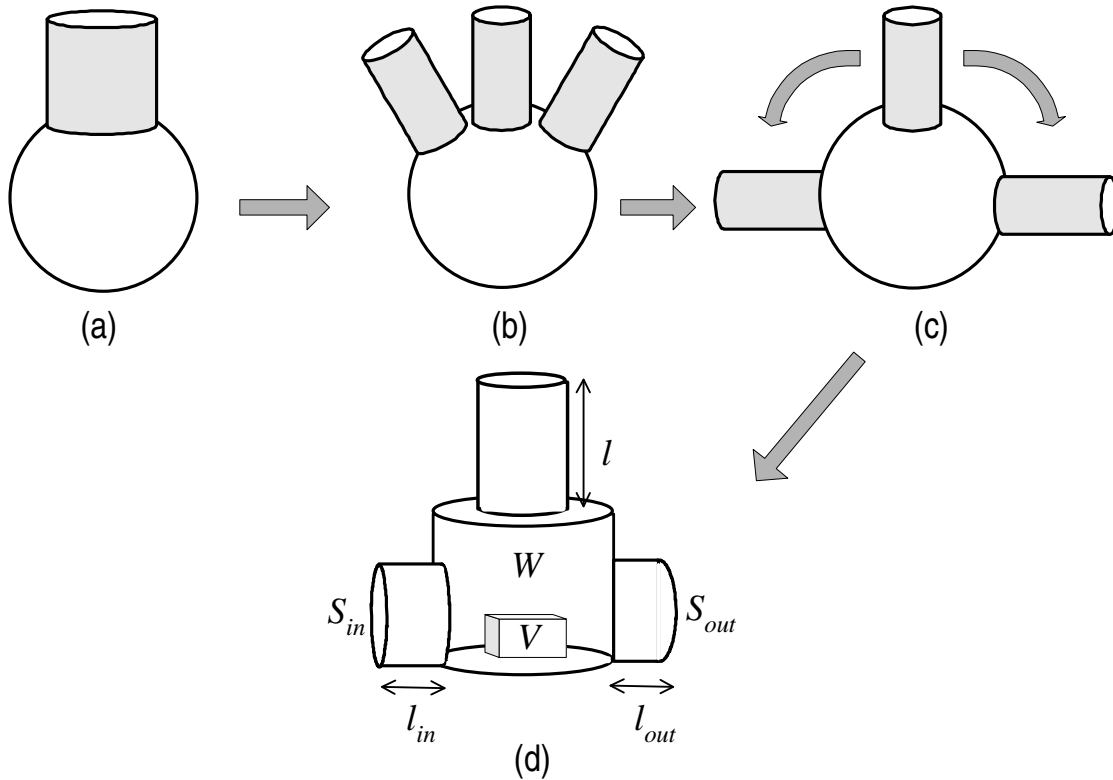

Figure 4. Outlines of a resonator with two openings: l -throat length, V -object's volume, W -cavity volume, S -cross-sectional area, "in"-inlet, "out"-outlet.

analogy between an acoustic and an electric circuit, a Helmholtz resonant frequency of this open system is obtained as the following:

$$f = \left[\left\{ S / (l - l_c) + S_{in} / (l_{in} - l_{inc}) + S_{out} / (l_{out} - l_{outc}) \right\} / (W - V) \right]^{0.5} \cdot c / (2\pi) \quad (2)$$

where "in" means "inlet", "out" means "outlet", l_{inc} is an open end correction of an inlet throat [m], and l_{outc} is an open end correction of an outlet throat [m].

Detection of resonant frequency

The way of determining resonant frequency should be selected very carefully because inaccurate frequency decreases the volume prediction accuracy. The resonant frequency was detected by spectrum analysis of acoustic response signal obtained by sending an acoustic wave into a resonator. (See Figure 5.) Frequency characteristics of the entire system including resonator, speaker, microphone and amplifier should be examined carefully. But actually the resonant frequency can be found without characterizing the entire system, because its peak should be prominent among the other peaks in the spectrum of a response signal. A chirp wave limited within a certain range

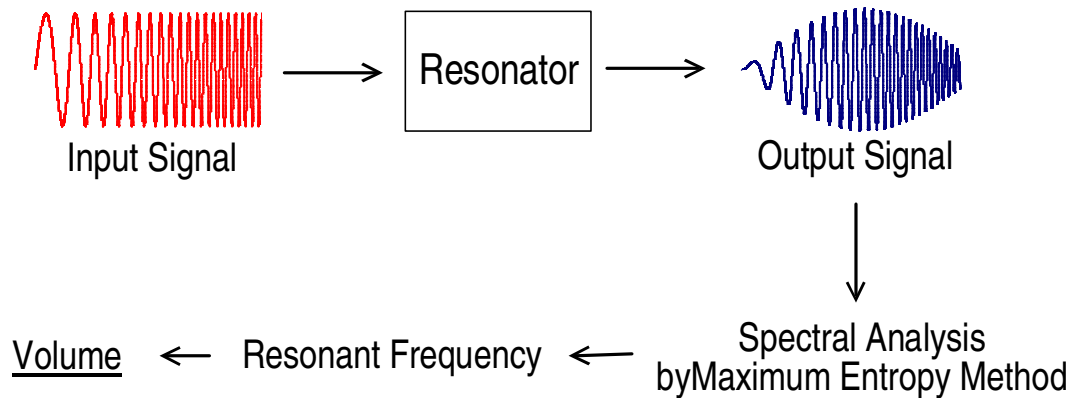

Figure 5. Data-acquisition and data-processing for determining volume.

of frequency was used as an input signal. Because its acoustic energy density is higher than white noise energy, the use of a chirp wave is advantageous in an s/n ratio. Fourier transform usually used for frequency analysis demands enough long data length for high spectral resolution. In order to obtain frequency resolution of 0.1Hz, for example, measurement data length requires at least 10 seconds. In the case of a measurement system with a conveyor, measurement for each of the samples on a belt cannot be allotted a long time. Therefore frequency characteristics of signals were detected by using the maximum entropy method (MEM) because of its higher resolution of frequency.

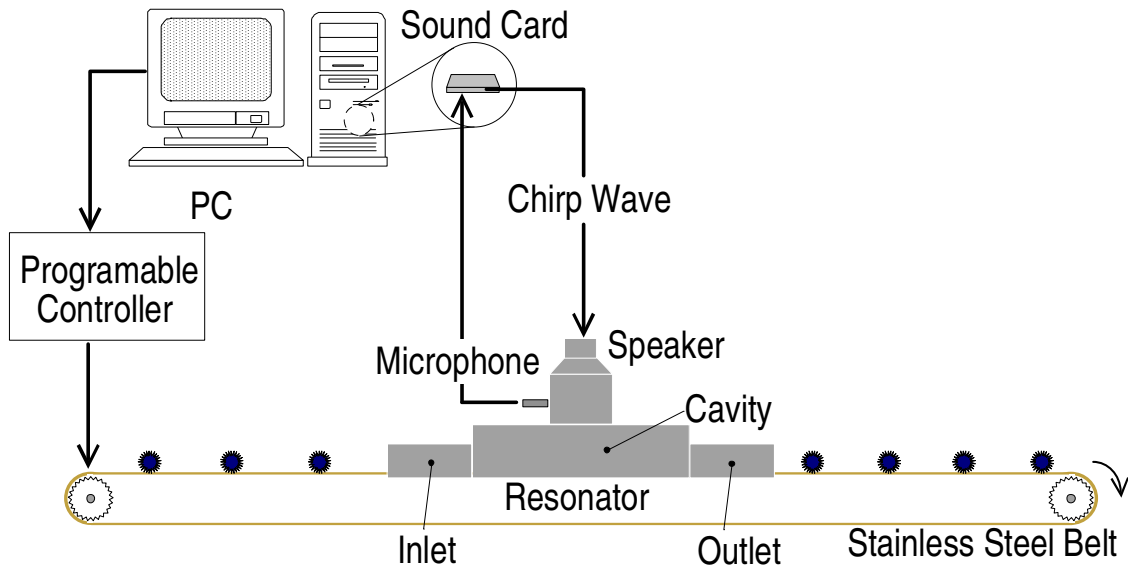

Figure 6. A schematic diagram of an automatic and continuous measurement system for food volume.

MATERIALS AND METHODS

Sample preparation

A wooden block of $56 \times 56 \times 12$ mm, a metallic bar of 14mm in diameter \times 50mm in length and cooked rice were used in this study.

Measurement system

Figure 6 shows the outline of the measurement system. The stainless steel belt passes through two openings of the resonator. A chirp sound of 120-250Hz was transmitted into the resonator, and a response signal was received by the dynamic microphone. These signals were sent to the personal computer equipped with a sound card. A chirp signal of 95ms was repeated continuously with a silent break of 235ms. Every measurement interval was 330ms. The conveyor belt was controlled with a sequencer. Its speed was 15, 30, 45mm/s.

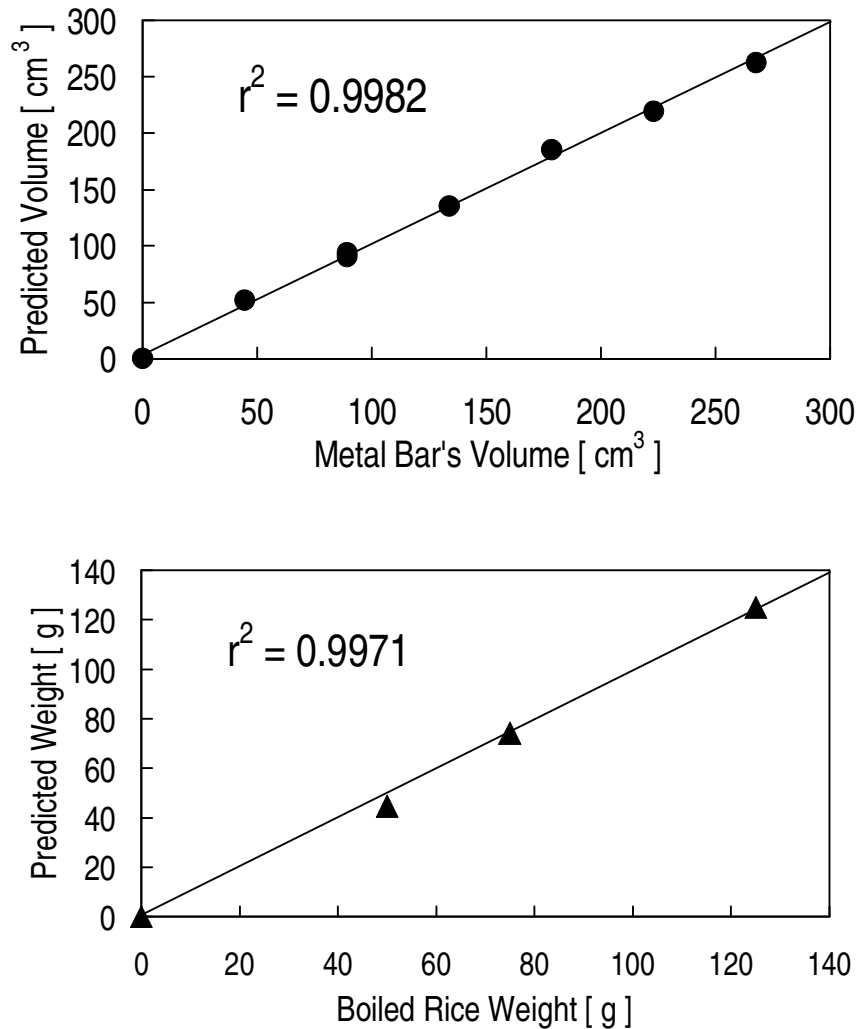

Figure 7. Results of volume prediction for metallic bars and rice without moving a conveyor belt.

RESULTS AND DISCUSSION

Measurement performance

Figure 7 shows the results of volume prediction for metallic bars and rice without moving the conveyor belt. Both coefficients of determination were over 0.99. This means that this measurement system has practically enough accuracy for volume measurement.

Influence of sample movement

Figure 8 shows the transition of resonant frequency f in moving a wooden block on the conveyor belt at 45mm/s. As the wooden block got closer to the inlet throat, f became lower, and finally became lowest when the wooden block was in the center of the throat. It was caused by a decrease of the cross-section area S_{in} in Equation 2. After that, f began to increase and reached maximum when the wooden block was placed in the center of the cavity. The volume of wooden block was calculated from the maximum of f . Later, f once fell to minimum and then returned to frequency when empty again. There are two dips before and after peak. From this pattern, the position of the object can be monitored without any locating device.

Figure 9 shows the results of volume prediction for wooden blocks moving by the conveyor belt. The prediction accuracy in Figure 9 was less than in Figure 7. Because the lengths of a metal bar and a wooden block are almost the same, it seems to be caused not by the objects dimension, but by its movement. In measuring volume, the object must not be put close to the throat and there is a “sweet spot” for giving a good prediction of volume (Nishizu 1998). When an object is not within the “sweet spot”, the accuracy should be reduced largely. The range of spot depends on the size of the open end correction. Figure 10 shows the transition of f around a peak at the belt speed of 30mm/s. The peak shape is steep and does not look like a plateau. It means that the range of the “sweet spot” is narrower than the sample length. If such range becomes wider, the peak shape should come to look like a plateau. Even at the summit of the line,

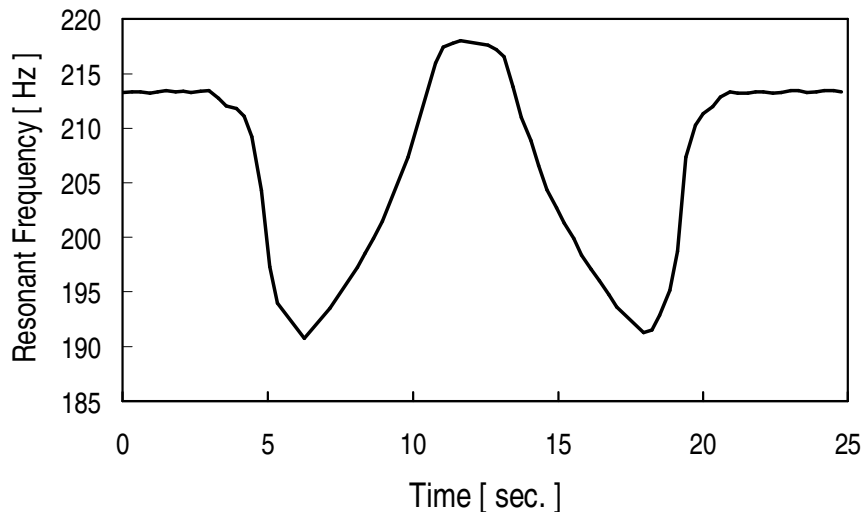

Figure 8. An example of transition of resonant frequency in moving a wooden block.

Nishizu, T., Y. Ikeda, Y. Torikata, S. Manmoto, T. Umehara, and T. Mizukami. “Automatic, Continuous Food Volume Measurement with a Helmholtz Resonator”. *Agricultural Engineering International: the CIGR Journal of Scientific Research and Development*. Manuscript FP 01 004. Vol. III.

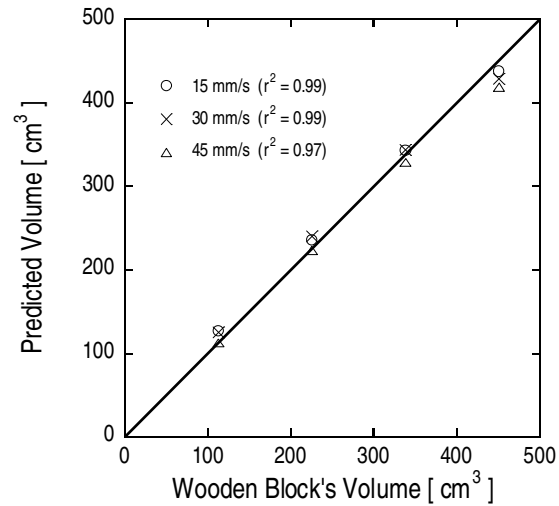

Figure 9. Results of volume prediction for wooden blocks moving by a conveyor belt at 15, 30, and 45mm/s.

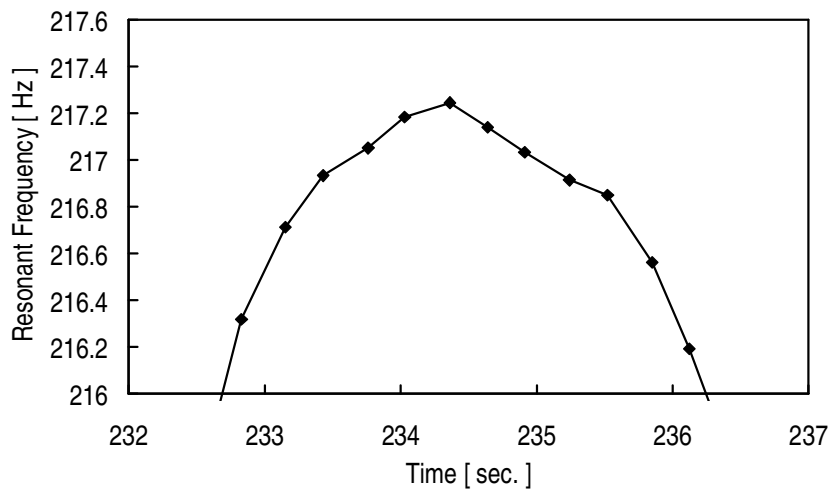

Figure 10. A peak of resonant frequency transition for wooden blocks moving at 30mm/s.

the object may not have been within the “sweet spot”. For improvement of accuracy, the measurement interval has to be shortened and the “sweet spot” range must be widened.

CONCLUSIONS

- An automatic and continuous Food volume measurement system with a new type of

Nishizu, T., Y. Ikeda, Y. Torikata, S. Manmoto, T. Umehara, and T. Mizukami. “Automatic, Continuous Food Volume Measurement with a Helmholtz Resonator”. *Agricultural Engineering International: the CIGR Journal of Scientific Research and Development*. Manuscript FP 01 004. Vol. III.

Helmholtz resonator was developed. The resonator has two openings through which the conveyor belt passes. The belt was controlled with a sequencer. The measurement test was conducted at 15, 30, 45mm/s.

- Chirp sound of 120-250Hz was transmitted into the resonator, and its response was caught with the dynamic microphone. The resonant frequency was determined from a spectrum obtained by the maximum entropy method (MEM). Duration time of the chirp sound was 95ms, and the measurement interval was 330ms.
- An equation about the relationship between the resonant frequency and the volume of the object placed in the resonator was proposed. As a result of the measurement test using metallic bars and rice without moving, the coefficients of determination between the real volumes and the values calculated by the proposed equation were over 0.99.
- The volume of objects moving at 15, 30 and 45mm/s were measured. As the speed increased, the prediction accuracy decreased. It was caused by object's moving out of the center of the resonator during 95ms.

REFERENCES

- Kato, K. 1992. New density sorting method for fruits by electric volume measurement (part 2). *In Proc. of the 51st annual meeting of the Japanese Society of Agricultural Machinery*, 275-276. Tokyo, Japan, 5-8 April.
- Kato, K. 1997. Electrical density sorting and estimation of soluble solids content of watermelon. *Journal of Agricultural Engineering Research* 67(2):161-170.
- Nishizu, T. and Y. Ikeda. 1995. Volume Measuring System by Acoustic Method for Agricultural Products (Part 1). *Journal of the Japanese Society of Agricultural Machinery* 57(5):47-54.
- Nishizu, T. and Y. Ikeda. 1998. Volume measurement of agricultural products by acoustic method (part 2). *In Proc. of the 57th annual meeting of the Japanese Society of Agricultural Machinery*, 301-302. Yamagata, Japan, 2-4 April.
- Sugiura, T., Honjo, H., Abe, K., Kuwata, Y., Yoshida, H., Yoshida, A., Kitamura, M. and T. Haji. 1996. Nondestructive estimation of brix in peach fruit by using specific gravity. *Journal of the Japanese Society for Horticultural Science* 65:154-155.
- Zaltzman, A., Verma, B. P., and Z. Schmilovitch. 1987. Potential of quality sorting of fruits and vegetables using fluidized bed medium. *Transactions of the ASAE* 30(3):823-831.

Nishizu, T., Y. Ikeda, Y. Torikata, S. Manmoto, T. Umehara, and T. Mizukami. "Automatic, Continuous Food Volume Measurement with a Helmholtz Resonator". *Agricultural Engineering International: the CIGR Journal of Scientific Research and Development*. Manuscript FP 01 004. Vol. III.